

1

Green-Cap(ELECTRIC DOUBLE LAYER CAPACITORS)



Green-Cap (Electric Double Layer Capacitors)

1. Polarity

Be sure verify the polarity of the capacitor before use. If a reverse voltage is applied for a long time, capacitor lifetime is shortened and serious damage such as electrolyte leakage may occur.

Further more, there may be leftover electric charge from capacitor testing that could damage other circuit components such as the low-withstanding voltage parts of semiconductors, etc.

2. Voltage

If a Green-Cap is used at a voltage exceeding its rated voltage, not only is its life shortened, but depending on the actual voltage, gas generated by electrochemical reactions inside the capacitor may cause it to leak or rupture

3. Ambient Temperature

(1) Capacitor life is affected by operating temperature. In general, lowering ambient temperature by 10°C will double the life of a capacitor. Use the capacitor at the lowest possible temperature under the maximum guaranteed temperature.

(2) Operation above the maximum specified temperature not only shortens capacitor life, but can also cause serious damage such as electrolyte leakage.

Verify the operating temperature of the capacitor by taking into consideration not only the ambient temperature and temperature inside the unit, but also the radiation from heat generating elements inside the unit (power transistors, IC's, resistors, etc.) and self-heating due to ripple current.

Be careful not to place heat-generating elements across from the capacitor on the opposite of the PCB.

4. Ripple Current

Green-Cap has a higher internal resistance than do electrolytic capacitors and are more susceptible to internal heat generation when exposed to ripple current. When the temperature of the element rises, a reacting current flows inside the Green-Cap, generating reaction products and raising internal resistance even further. This makes it difficult to maintain capacitance. Set the allowable limit for the ripple current-induced rise in capacitor temperature to 3°C measured at the surface of the capacitor

5. Heat Stress During Soldering

Excessive heat stress may result in the deterioration of the electrical characteristics of the capacitor, loss of air-tightness, and electrolyte leakage due to the rise in internal pressure

(1) If the tip of the soldering iron touches the capacitor's external sleeve, the sleeve will melt or break.

(2) Use the general reference chart below to set soldering temperature and time.

(3) When soldering with a soldering iron, do not touch the tip to the body of the capacitor.

Minimize the time that soldering iron is in contact with the capacitor terminals.

(4) When using equipment such as a UV curing oven for pre-heating and adhesive hardening, do not set the temperature above 150°C .

If the temperature is higher than this, the external sleeve may crack and the end seal may suffer reduced performance.

(5) Never perform reflow soldering on Green-Cap using infrared or atmospheric methods.

6. Circuit Board Cleaning

Circuit board can be immersed or ultrasonically cleaned using suitable cleaning solvents for up to 5 minutes and up to 60°C maximum temperature. The board should be thoroughly rinsed and dried. Recommended cleaning solvent include. Pine Alpha ST-100S, Sunelec B-12, DK beclear CW-5790, Aqua Cleaner 210SEP, Cold Cleaner P3-375, Telpen Cleaner EC 7R, Clean-thru 750H, Clean-thru 750L Clean-thru 710M, Techno Cleaner 219, Techno Care FRV-1

- Consult with us if you are using a solvent other than any of those listed above
- The use of ozone depelting cleaning agents are not recommended in the interest of protecting the environment

PART NUMBER SYSTEM

Single Cell Part Number System

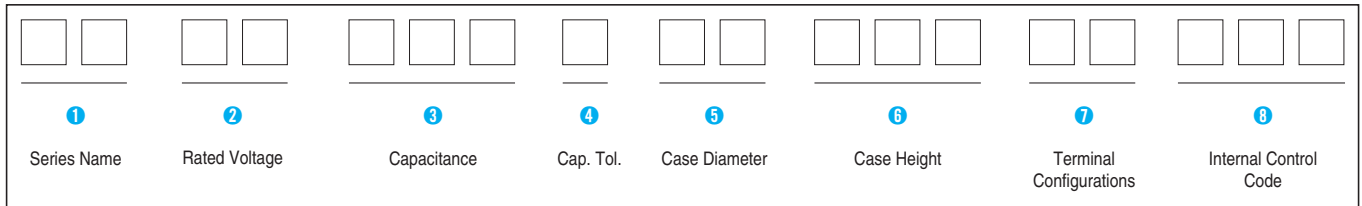

1 Series Name
See page 4.

2 Rated Working Voltage

WV	2.5	2.7	3.0
CODE	0E	5U	0U

3 Capacitance

ex) 1F 105
10F 106
100F 107
1000F 108

4 Capacitance Tolerance

Tolerance (%)	±20	0~20%
Code	M	W

5 Case Diameter

ex) Ø10 10
Ø16 16
Ø18 18

6 Case Height

ex) 20mm 020
25mm 025
30mm 030

7 Terminal Configurations

Terminal Configurations	Code
Radial Type(LEAD)	BB
Lug Terminal for Soldering	HA
Screw Terminal Type	SB
Threaded Terminal Type	TH
Weldable Terminal Type	WD

Module Part Number System

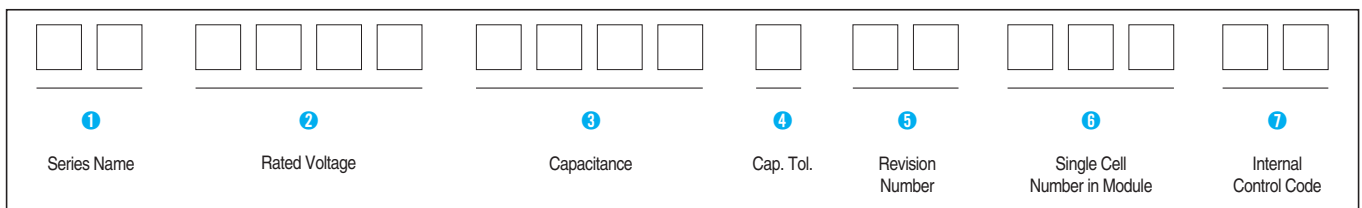

1 Series Name
See page 4.

2 Rated Working Voltage

ex) 5.0V 0050
13.5V 0135
135V 1350

3 Capacitance

ex) 1.6F 0016
16F 0160
160F 1600

4 Capacitance Tolerance

Tolerance (%)	0 ~ +20
Code	W

5 Revision Number

ex) 01, 02

6 Single Cell Number in Module

ex) 10ea 010

PACKING

● BLUCK TYPE PACKING

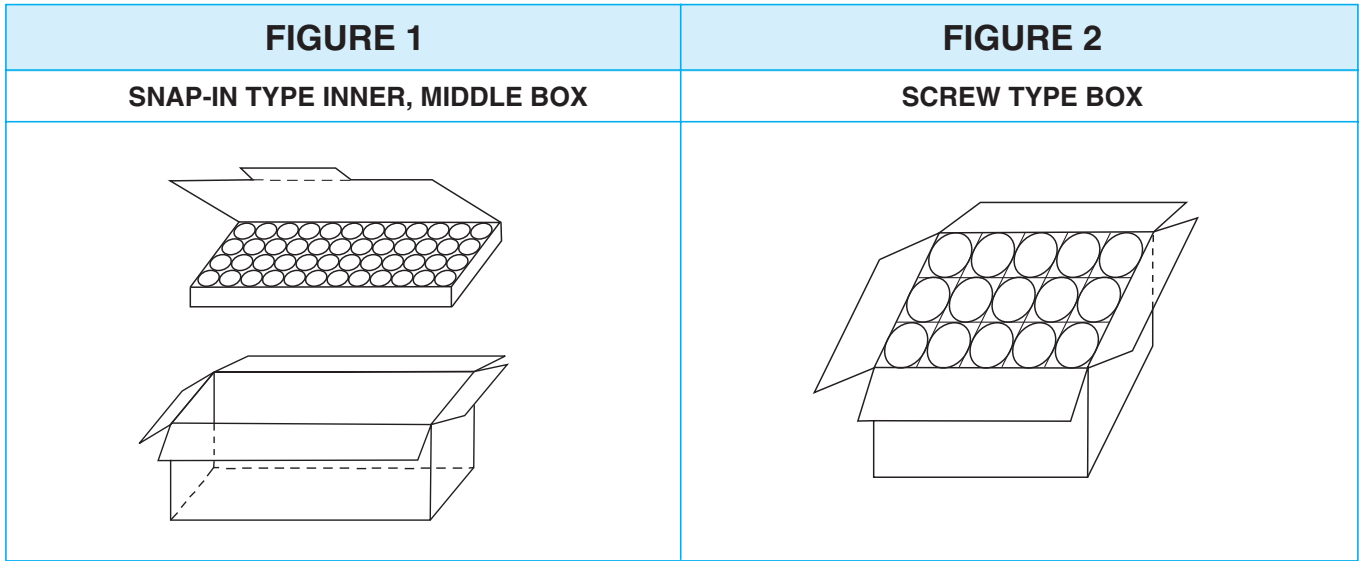

● SNAP-IN TYPE(DB series) PACKING Quantity (pcs) / BOX (FIGURE 1)

SIZE		SNAP-IN(QUANTITY)	
ØD	L	INNER BOX	MIDDLE BOX
22	35, 45	150	450
30	45	50	200
	60	50	150
35	50 ~ 60	50	150

● SCREW TYPE(DP series) PACKING Quantity (pcs) / BOX (FIGURE 2)

SIZE		SCREW(QUANTITY)
ØD	L	
35	68 ~ 120	60
51	100, 130	30
64	120, 130	25
76	150	16

● TABLESS TYPE(DH series) PACKING Quantity (pcs) / BOX (FIGURE 1)

SIZE		TABLESS(QUANTITY)
ØD	L	
60	51 ~ 138	20

● RADIAL TYPE PACKING

● DS series BULK PACKING QUANTITY (pcs) / BOX

SIZE		BULK(QUANTITY)		
ØD	L	V-Bag	INNER BOX	MIDDLE BOX
8	20	300	2400	9600
10	20	200	1600	6400
	30	200	1200	4800
16	25	50	500	2000
18	40	50	300	1200

DM Green-Cap Module

- Low internal resistance
- Balancing and overvoltage protection of individual cell
- Efficient heat Transfer to outside
- Compliant with RoHS requirement

Application

- Next Generation Vehicle(FCEV, HEV) & Heavy Duty Transportation
- Short term UPS and telecommunications
- Portable Power Tool
- Wind Turbine Pitch System
- Electric Scooter
- Heavy Duty Transportation
- Golf Car



● Product & Spec.

Item	Characteristics	
Capacitance tolerance	0% ~ +20% at 120Hz, 20°C	
Operating temperature range	-40 ~ 60°C or -40 ~ 65°C or -25 ~ 70°C	
Storage Temperature Range	-40 ~ 70°C	
Low temperature characteristics	Capacitance change	Within $\pm 5\%$ of initial value at +20°C
	Internal resistance	Within 150% of initial value at +20°C
Endurance(60°C)	Test time	1000 hours
	Capacitance change	Within $\pm 30\%$ of initial specified value
	Internal resistance	Within 100% of initial specified value
Shelf life (60°C)	After 1000 hours no load test same as endurance	
Life Time at RT ⁽¹⁾	10 years	(1) $\Delta Cl < 30\%$ and $\Delta ESR < 200\%$ of initially specified value, respectively and LC < specified value (2) Cycle : between rated voltage and half rated voltage under constant current at 25°C
Cycle Life (25°C) ⁽¹⁾⁽²⁾	500,000 cycles	

Part Number	Rated Voltage	Max. Operating Voltage	Capacitance (F)	ESR, 1KHz (mΩ)	ESR, DC (mΩ)	Max. Continuous Current (A)	Max. Peak Current (A)	Stored Energy (Wh)	Specific Energy (Wh/kg)	Cell Composition		Dimension(mm)			Weight (kg)
										ITEM	EA	L	W	T	
DM00500015W01002	5	5.4	1.5	110	143	0.2	3.1	0.005	1.47	2.7V 3F	2	23	10	18	0.0034
DM00500025W01002	5	5.4	2.5	53	69	0.3	5.3	0.009	1.80	2.7V 5F	2	23	12	22	0.005
DM01500666W01006	15	16.2	66.6	18	30	20	167	2.43	4.05	2.7V 400F	6	117	81	80	0.6
DM01505000W01006	15	16.2	500	1.7	2.4	150	1705	15.63	2.61	2.7V 3000F	6	417	68	157	6
DM04501111W01018	45	48.6	111.1	5.6	8.1	100	1316	31.25	2.40	2.7V 2000F	18	418	191	121	13
DM04501666W01018	45	48.6	166.6	14.5	18	150	1705	46.88	3.13	2.7V 3000F	18	481	191	157	15
DM07500266W01060	75	81	26.6	75	52.5	40	333	20.83	2.60	2.7V 400F	60	372	316	90	8
DM12500600W01050	125	135	60	15	20	150	1705	130.21	2.00	2.7V 3000F	50	1000	350	310	70

Note: Other Green-Cap modules are supplied on custom-made basis. Dimension and Weight could be changed without notice.

Green-Cap (ELECTRIC DOUBLE LAYER CAPACITORS)

NEW
DH

Threaded Terminal Type,
High Power Density Type

- High Power Density
- Rapid charge and discharge
- Ultra-low internal resistance



Item	Characteristics	
Operating temperature range	-40 ~ 65°C	
Rated Voltage	2.7 VDC	
Capacitance tolerance	0% ~ +20%	
Low temperature characteristics	Capacitance change	Within $\pm 5\%$ of initial value at +20°C
	Internal resistance	Within 150% of initial value at +20°C
Endurance (65°C)	Test time	1000 hours
	Capacitance change	Within $\pm 30\%$ of initial specified value
	Internal resistance	Less than 100% of initial specified value
Shelf life (70°C)	After 1000 hours no load test same as endurance	
Life Time at RT ⁽¹⁾	10 years	(1) $I\Delta C I < 30\%$ and $\Delta ESR < 200\%$ of initially specified value, respectively and $LC < \text{specified value}$
Cycle Life (25°C) ⁽¹⁾⁽²⁾	500,000 cycles	(2) Cycle : between rated voltage and half rated voltage under constant current at 25°C

● DRAWING

Unit : mm

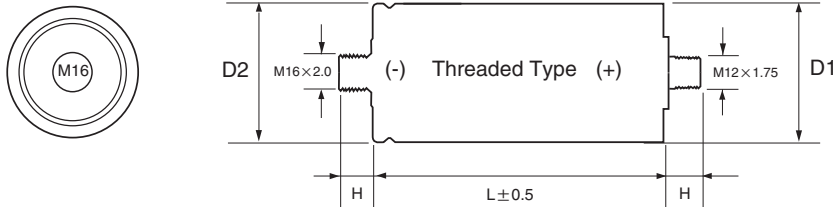

Size(mm)		
H	D1	D2
(± 0.2)	(± 0.2)	(± 0.5)
3.5	$\varnothing 60.4$	$\varnothing 60.7$

● CHARACTERISTIC LIST & DIMENSIONS

Rated Voltage	Capacitance (F)	ESR, 1KHz (m Ω)	ESR, DC (m Ω)	LC (72hr) (mA Max.)	Max Continuous Current(A)	Max Peak Current(A)	Specific Energy		Weight (g)	Volume (ml)	Dimension $\varnothing D \times L$ (mm)
							(Wh/kg)	(Wh/L)			
2.7	650	0.50	0.70	1.5	34	577	2.99	4.50	220	146	60.4 \times 51
	1200	0.38	0.50	2.7	63	955	3.86	5.73	315	212	60.4 \times 74
	1600	0.34	0.45	3.0	85	1233	4.63	6.65	350	244	60.4 \times 85
	2000	0.26	0.35	4.2	106	1588	4.94	6.93	410	292	60.4 \times 102
	3000	0.21	0.28	5.2	150	1975	5.63	7.68	540	395	60.4 \times 138

Rev. 02, Date: 13.03.2012

NEW

DH Weldable Terminal Type,
High Power Density Type

- High Power Density
- Rapid charge and discharge
- Ultra-low internal resistance



Green-Cap(EDLC)

Item	Characteristics	
Operating temperature range	-40 ~ 65°C	
Rated Voltage	2.7 VDC	
Capacitance tolerance	0% ~ +20%	
Low temperature characteristics	Capacitance change	Within ±5% of initial value at +20°C
	Internal resistance	Within 150% of initial value at +20°C
Endurance (65°C)	Test time	1000 hours
	Capacitance change	Within ±30% of initial specified value
	Internal resistance	Less than 100% of initial specified value
Shelf life (70°C)	After 1000 hours no load test same as endurance	
Life Time at RT ⁽¹⁾	10 years	(1) ΔC < 30% and ΔESR < 200% of initially specified value, respectively and LC < specified value
Cycle Life (25°C) ⁽¹⁾⁽²⁾	500,000 cycles	(2) Cycle : between rated voltage and half rated voltage under constant current at 25°C

● DRAWING

Unit : mm

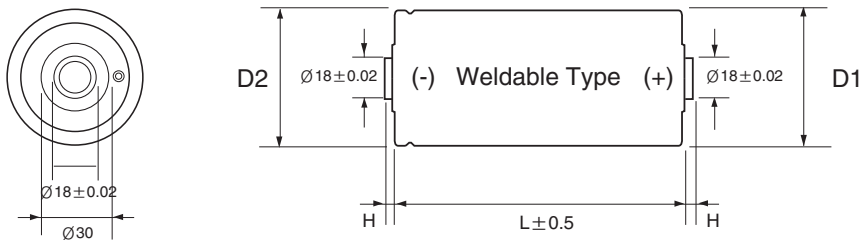

Size(mm)		
H	D1	D2
(±0.2)	(±0.2)	(±0.5)
3.5	∅60.4	∅60.7

● CHARACTERISTIC LIST & DIMENSIONS

Rated Voltage	Capacitance (F)	ESR, 1KHz (mΩ)	ESR, DC (mΩ)	LC (72hr) (mA Max.)	Max Continuous Current(A)	Max Peak Current(A)	Specific Energy		Weight (g)	Volume (ml)	Dimension ∅D×L(mm)
							(Wh/kg)	(Wh/L)			
2.7	650	0.50	0.70	1.5	34	577	3.06	4.50	215	146	60.4 × 51
	1200	0.38	0.50	2.7	63	955	3.92	5.73	310	212	60.4 × 74
	1600	0.34	0.45	3.0	85	1233	4.70	6.65	345	244	60.4 × 85
	2000	0.26	0.35	4.2	106	1588	4.94	6.93	410	292	60.4 × 102
	3000	0.21	0.28	5.2	150	1975	5.68	7.68	535	395	60.4 × 138

Green-Cap (ELECTRIC DOUBLE LAYER CAPACITORS)

Upgrade

DP

Screw Terminal Type,
Standard Type



- High Power Density
- Rapid charge and discharge
- Charge and discharge efficiency are higher than in batteries

Item	Characteristics	
Operating temperature range	-25 ~ 70°C	-40 ~ 60°C
Rated Voltage	2.5 VDC	2.7 VDC
Capacitance tolerance	-20 ~ +20% or 0% ~ 20% at 20°C	
Low temperature characteristics	Capacitance change	Within $\pm 5\%$ of initial value at +20°C
	Internal resistance	Within 150% of initial value at +20°C
Endurance (2.5V:70°C, 2.7V:60°C)	Test time	1000 hours
	Capacitance change	Within $\pm 30\%$ of initial specified value
	Internal resistance	Less than 100% of initial specified value
Shelf life (70°C)	After 1000 hours no load test same as endurance	
Life Time at RT ⁽¹⁾	10 years	(1) $I\Delta CI < 30\%$ and $\Delta ESR < 200\%$ of initially specified value, respectively and $LC <$ specified value
Cycle Life (25°C) ⁽¹⁾⁽²⁾	500,000 cycles	(2) Cycle : between rated voltage and half rated voltage under constant current at 25°C

● DRAWING

Unit : mm

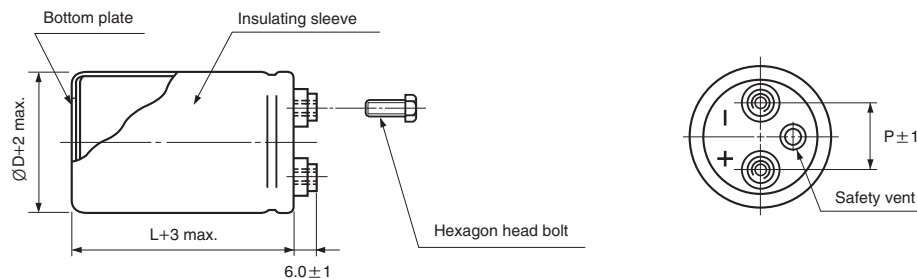

ØD	P	Bolt
35	12.7	M5
51	22.0	M5
63.5	28.6	M5
76.2	31.8	M6
89	31.8	M6

● ANGLE DRAWING & SIZE TABLE(See Page 184)

● CHARACTERISTIC LIST & DIMENSIONS

Rated Voltage	Capacitance (F)	ESR, 1KHz (mΩ)	ESR, DC (mΩ)	LC (72hr) (mA Max.)	Max Continuous Current(A)	Max Peak Current(A)	Specific Energy		Weight (g)	Volume (ml)	Dimension ØD×L(mm)
							(Wh/kg)	(Wh/L)			
2.5	400	5.3	12.0	1.0	20	86.2	4.34	5.31	80	65	35 × 68
	700	3.5	10.0	1.8	35	109	4.40	5.26	138	115	35 × 120
	1700	2.0	5.0	4.3	85	223.6	5.18	2.56	285	266	51 × 130
	3000	0.9	1.2	7.5	150	815.2	5.85	6.33	445	412	63.5 × 130
2.7	400	3.0	5.0	1.1	22	180	5.79	6.19	70	65	35 × 68
	700	2.5	4.5	1.9	37	343	6.01	6.14	120	115	35 × 120
	1700	1.5	1.6	4.6	90	460	6.62	6.48	260	266	51 × 130
	3000	0.8	1.0	8.1	150	1012	7.02	7.38	435	412	63.5 × 130
	5000	0.8	1.0	12.5	250	1042	6.89	6.34	630	684	76.2 × 150
	6500	0.7	0.9	17.6	343	1186	7.02	7.38	435	412	89 × 150

Rev. 02, Date: 13.03.2012

DB Snap-in Terminal Type, Standard Series



- Endurance : 2.5V 70°C 1000 hours, 2.7V 60°C 1000 hours
- The middle size and high capacitance, low resistance
- Charge and discharge efficiency are higher than in batteries

Item	Characteristics	
Operating temperature range	-25 ~ +70°C	-40 ~ +60°C
Rated Voltage	2.5 VDC	2.7 VDC
Capacitance tolerance	-20 ~ +20% or 0% ~ +20% at 20°C	
Low temperature characteristics	Capacitance change	Within ±5% of initial value at +20°C
	Internal resistance	Within 150% of initial value at +20°C
Endurance (2.5V:70°C, 2.7V:60°C)	Test time	1000 hours
	Capacitance change	Within ±30% of initial specified value
	Internal resistance	Less than 100% of initial specified value
Shelf life (70°C)	After 1000 hours no load test same as endurance	
Life Time at RT ⁽¹⁾	10 years	(1) IΔCI < 30% and ΔESR < 200% of initially specified value, respectively and LC < specified value (2) Cycle : between rated voltage and half rated voltage under constant current at 25°C
Cycle Life (25°C) ⁽¹⁾⁽²⁾	500,000 cycles	

DRAWING

Unit : mm

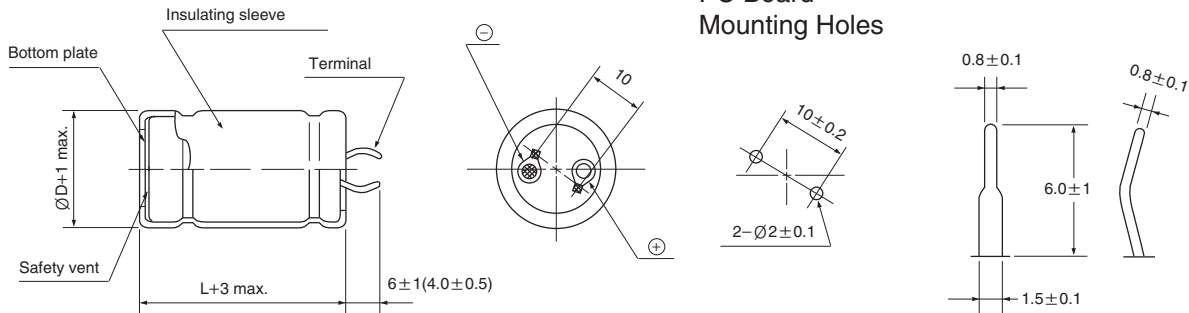

CHARACTERISTIC LIST & DIMENSIONS

Rated Voltage	Capacitance (F)	ESR, 1KHz (mΩ)	ESR, DC (mΩ)	LC (72hr) (mA Max.)	Max Continuous Current(A)	Max Peak Current(A)	Specific Energy		Weight (g)	Volume (ml)	Dimension $\varnothing D \times L$ (mm)
							(Wh/kg)	(Wh/L)			
2.5	100	15.0	35.0	0.25	5.3	27.7	3.62	5.07	24	17	22 × 45
	200	10.0	20.0	0.50	10.4	50.0	4.13	5.46	42	32	30 × 45
	300	6.0	15.0	0.75	15.3	68.2	4.20	5.41	62	48	35 × 50
	360	6.0	12.0	0.90	18.5	84.6	4.17	5.41	75	58	35 × 60
	400	6.0	10.0	1.00	20.8	100.0	4.63	6.01	75	58	35 × 60
2.7	100	8.0	10.0	0.27	6.4	67.5	4.82	5.92	21	17	22 × 45
	200	7.0	9.0	0.54	12.3	96.4	5.33	6.37	38	32	30 × 45
	300	3.5	5.0	0.91	18.8	162.0	5.33	6.31	57	48	35 × 50
	360	3.2	3.8	0.97	22.7	205.2	5.21	6.31	70	58	35 × 60
	400	3.2	3.8	1.08	25	214.2	5.79	7.02	70	58	35 × 60

※ $\varnothing 35$ 4 pin type terminal drawing is same see pages 146.

Green-Cap (ELECTRIC DOUBLE LAYER CAPACITORS)

DS Radial Type, Standard Series

- Endurance : 2.5V 70°C 1000 hours, 2.7V 60°C 1000 hours
- The small size and high capacitance, low resistance
- Can be charge and discharge more times than secondary batteries

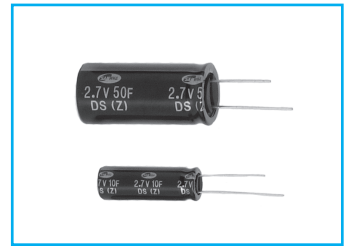

Item	Characteristics	
Operating temperature range	-25 ~ +70°C	-40 ~ +60°C
Rated Voltage	2.5 VDC	2.7 VDC
Capacitance tolerance	-20 ~ +20% at 20°C	
Low temperature characteristics	Capacitance change	Within ±5% of initial value at +20°C
	Internal resistance	Within 150% of initial value at +20°C
Endurance (2.5V:70°C, 2.7V:60°C)	Test time	1000 hours
	Capacitance change	Within ±30% of initial specified value
	Internal resistance	Less than 100% of initial specified value
Shelf life (70°C)	After 1000 hours no load test same as endurance	
Life Time at RT ⁽¹⁾	10 years	(1) ΔC < 30% and ΔESR < 200% of initially specified value, respectively and LC < specified value
Cycle Life (25°C) ⁽¹⁾⁽²⁾	500,000 cycles	(2) Cycle : between rated voltage and half rated voltage under constant current at 25°C

● DRAWING

Unit : mm

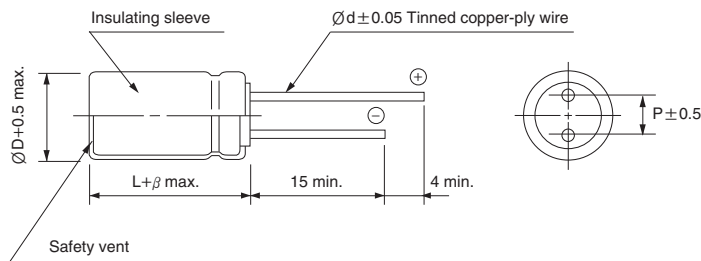

ØD	8	10	16	18	22
P	3.5	5	7.5	7.5	10.0
Ød	0.6	0.6	0.8	0.8	1.0
β	1.5	2.0		3.0	

● CHARACTERISTIC LIST & DIMENSIONS

Rated Voltage	Capacitance (F)	ESR, 1KHz (mΩ)	ESR, DC (mΩ)	LC (72hr) (mA Max.)	Specific Energy		Specific Power		Weight (g)	Volume (ml)	Dimension ØD×L(mm)
					(Wh/kg)	(Wh/L)	(W/kg)	(W/L)			
2.5	3	140	350	0.008	1.63	2.59	1,339	2,132	1.6	1.0	8 × 20
	5	110	250	0.013	1.97	2.76	1,364	1,910	2.2	1.6	10 × 20
	10	65	120	0.025	2.48	3.68	1,786	2,653	3.5	2.4	10 × 30
	25	35	65	0.063	2.89	4.32	1,538	2,296	7.5	5.0	16 × 25
	60	20	30	0.150	3.77	5.12	1,812	2,456	13.8	10.2	18 × 40
2.7	3	60	90	0.008	2.17	3.02	6,943	9,669	1.4	1.0	8 × 20
	5	50	70	0.014	2.41	3.22	5,951	7,956	2.1	1.6	10 × 20
	10	30	50	0.027	3.49	4.30	6,033	7,426	2.9	2.4	10 × 30
	25	20	35	0.068	3.78	5.04	3,730	4,972	6.7	5.0	16 × 25
	50	10	20	0.140	4.40	4.97	3,803	4,297	11.5	10.2	18 × 40

Rev.02, Date: 13.03.2012